

- Input optical wavelength: 1550 nm
- Optical AGC: -6 to +2 dBm
- Thermally-stable DFB burst-mode laser
- Transmit wavelengths: 1310 nm, 1610 nm or CWDM
- Downstream bandwidth: 54/85/102/258 MHz to 1218 MHz
- Upstream bandwidth: 5 MHz to 42/65/85/204 MHz
- Output RF level: 20 dBmV/CH at 1002 MHz (typ.)
- Total input RF level: 20-40 dBmV

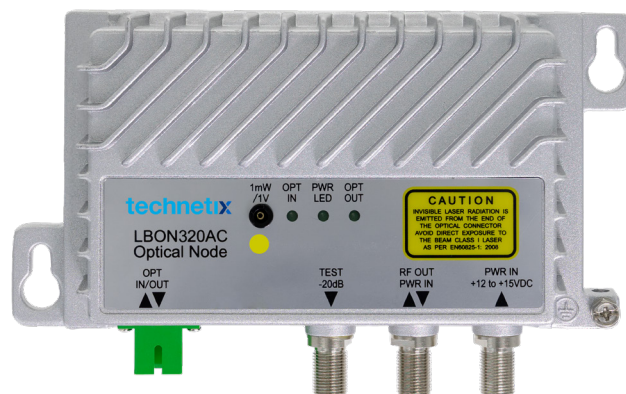

Other features

- RF bi-directional test point: -20 dB
- Power supply voltage: 12-15 VDC
- Pwr-On, Opt I/P, Opt TX LED indicators
- Optional Uninterruptible Power Supply (UPS) available

1.2 GHz customer premise RFoG ONU

Technetix' LBON320AC device is a 1218 MHz, DOCSIS® 3.1, compact, bi-directional optical node. It provides the ideal platform to deliver upstream and downstream DOCSIS, voice, video and high-speed data services over Fiber to the "x" (FTTx) applications.

The LBON320AC ONU includes Automatic Gain Control (AGC), burst-mode return lasers, and optional bandwidth splits.

Block diagram

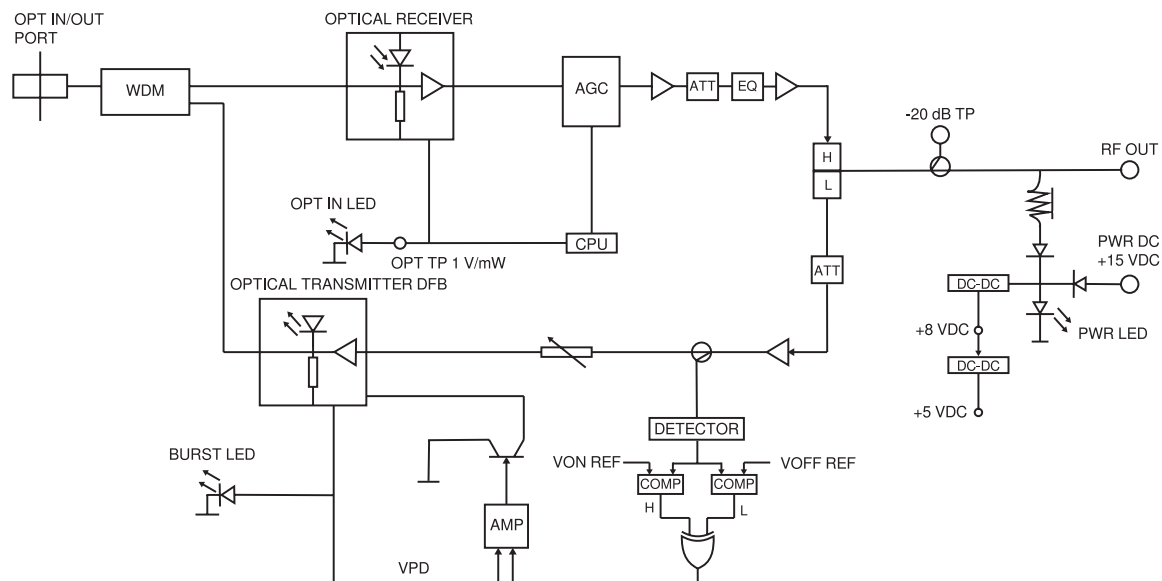

LBON320AC series device and performance specifications

Forward receiver

Parameter	LBON320AC			Units	Notes
	Min.	Typ.	Max.		
Optical receive wavelength	1540-1565			nm	
Monitor voltage	1			V/mW	
Optical input power	-6 to +2			dBm	
Frequency range	54-1218			MHz	1
Flatness of frequency response	$f = f_{min}-1218 \text{ MHz}$	± 1		dB	
Output return loss	$f = f_{min}-1218 \text{ MHz}$	16		dB	
Reference output level	@ 1000 MHz ($\pm 2 \text{ dB}$)	20		dBmV	2
Slope	$\pm 1 \text{ dB}$	6		dB	
Optical input return loss	45			dB	
C/N	50	51		dB	3
CTB			-65	dB	3
CSO			-60	dB	3

Return transmitter

Parameter	LBON320AC			Units	Notes
	Min.	Typ.	Max.		
Optical wavelength	1310 nm, 1610 nm or CWDM			nm	
Optical output power	2		3	mW	
RF input level	Total power			dBmV	
Dynamic input range		18			
Frequency range	5		42	MHz	1
Flatness of frequency response	f = 5-42 MHz	±0.75	±1	dB	
Input return loss	f = 5-42 MHz	16		dB	
Optical output return loss		45		dB	
TX OMI		35		%	5
Laser ON	±1.5 dB		15	dBmV	
Laser OFF	±1.5 dB		-4	dBmV	

Mechanical and environmental specifications

Parameter	LBON320AC			Units	Notes
	Min.	Typ.	Max.		
Total power consumption	15 VDC power pack			W	
Operating humidity	5-95%, non-condensing			%	
Operating temperature	-40°C to +65°C (-40°F to +149°F)			°C/°F	
Dimensions (H x W x D)	4.1"H x 6.7"W x 1.5"D (10.4H x 17.0W x 3.9D cm)			in/cm	
Weight	0.7 lb (0.3 kg)			lb/kg	

Notes

1	Other diplex splits available: 65/85 MHz, 85/102 MHz & 204/258 MHz.
2	3.5% OMI/CH
3	-1 dBm optical input; 3.5% OMI/CH; 54-550 MHz analog channels and digital compressed channels above 550-1218 MHz at levels 6 dB below equivalent video.
4	NPR at 30 dB. Measured using a receiver with an equivalent input noise (EIN) of <2.5 pA/Hz0.5 with a link budget of 23 dB (20 km fiber + passive loss). NPR test performed with 37 MHz noise loading.
5	SCTE 174 2018 with a single 39 dBmV tone; 35% ±1 dB.

Order information

LBON320AC	Fwd output level	Total return input power	Laser type	TX power	Optical connector	TX wavelength	Sub-split	Power adapter
	xx	xx	D	x	xx	xx	xx	xx
	20 = 20 dBmV	25 = 25 dBmV	D = DFB	2 = 2 mW	SA = SC/APC	31 = 1310 nm	45 = 42/54	00 = None
	36 = 36 dBmV	30 = 30 dBmV		3 = 3 mW		61 = 1610 nm	68 = 65/85	01 = N. America
						xx = CWDM	81 = 85/102	02 = Europe
							22 = 204/258	