

# AIMA-RRAS

- Bandwidth 5 ~ 204 MHz to meet EuroDOCSIS and DOCSIS 3.0/3.1 frequency band requirements
- RF output 48 dBmV at -6 dBm optical input and OMI of 6%
- Wide band receiver (1260~1620nm) to suit CWDM and DWDM applications
- Allows up to 64 receivers (4x16 Modules) in only 4 RU of space
- User-selectable MGC or AGC
- Easy to install due to RF-Paddle board backplane design
- Plug-and-play and hot-swappable
- Dedicated testport per return channel
- Fully FCC, CE, and RCM compliant
- Real-time alarm monitoring
- Full Band Capture offers automated and 7\*24 return path/upstream RF and data performance monitoring and analysis
- Help operators preemptively identify and address spectrum variances
- Lower capital expenses by eliminating the need for expensive test equipment
- Web-browser access eliminates the need for a thick client and a mobile APP is available
- An intuitive user interface similar as meter adapt to user's operating habits
- Improve network maintenance efficiency and increase customer satisfaction

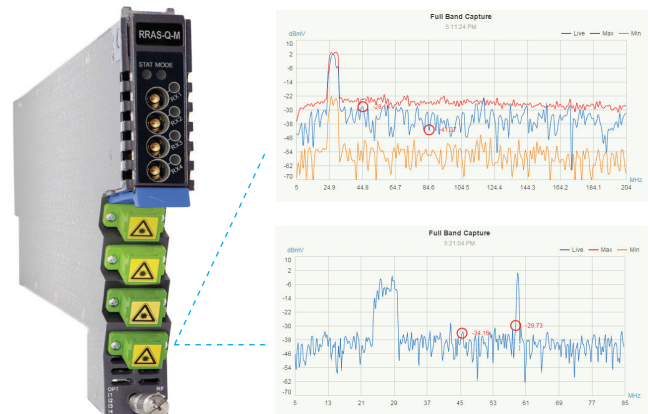

## Overview

The Technetix AIMA3000 RRAS series Analog Return Receiver - Standard is designed for multi-services operators to increase network-return capacities for the ever-growing demand for bandwidth, while minimizing physical headend space and power usage.

With the optional embedded Full Band Capture (FBC) module, it enables the operator to capture and monitor the return path spectrum helping the operator to quickly find and locate the upstream noise and the related upstream signal levels.

Next to above mentioned online management and controlling capabilities the can also be conveniently monitored and controlled through a computer directly connected to one of the Ethernet ports of the ASMM module.

## Block diagram

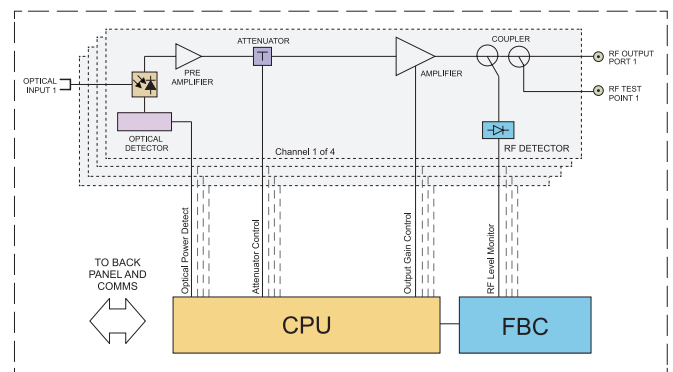

## Specifications

### Optical Performance

Optical wavelength	1260 nm to 1620 nm
Optical inputs	-18 dBm to +2 dBm
Output return loss	> 50 dB
Optical connectors	4 x SC/APC (1), FC/APC, LC/APC, E2000/APC

### RF Performance

RF bandwidth	5 MHz to 204 MHz
RF output level <sup>(2)</sup>	48 dBmV
RF flatness	± 0.75 dB (5 MHz to 204 MHz)
Gain adjustment	up to 52 dB in 0.5 dB increments (default 42 dB)
RF impedance	75 Ω
RF return loss	> 16 dB
Receiver isolation	> 60 dB
RF test point relative to RF output port	-20 dB ± 1 dB
RF connectors	4 x GSK-type female
RF test points	4 x Mini-SMB
Alarms and status	Front-panel LEDs, SNMP Traps

### Link Performance

CNR <sup>(3)</sup>	> 48 dB
IMD2 <sup>(4)</sup>	< -52 dBc
NPR <sup>(5)</sup>	> 35 dB (over dynamic range of 15 dB)

### General

Power supply	Powered via AIMA3000 backplane
Power consumption	< 8.5 W
Operating temperature	-5 °C to +55 °C
Storage temperature	-25 °C to +70 °C
Dimensions (WxDxH)	24.6 x 410 x 152.5 mm
Weight	0.95 kg

### With the FBC module

Frequency Capture	5 to 204 MHz
Dynamic range	60 dB
Spectrum Lines	3, including live, max hold and min hold
RBW	Up from 30KHz
VBW	Auto adaptable
Vertical Markers	2

#### Note:

- Standard option. Contact a Technetix sales representative for availability of other options.
- Measured in a typical system with -6 dBm optical input, 6% OMI, gain setting adjusted to maximum (the stated RF output level does not necessarily apply with other optical input levels). dBuV= 60+dBmV.
- Measured @ -2 dBm, 6% OMI, 4 channels.

### Order Details

A-RRAS-[W]-[X]-[Y]-[Z]

Analog Return Receiver - Standard

#### Options:

<b>W</b>	Optical Ports	<b>Z</b>	Bandwidth
<b>Q</b>	Quad <sup>(4)</sup>	<b>20</b>	5 ~ 204 MHz (Standard)
<b>X</b>	FBC function <sup>(1)</sup>		
<b>M</b>	With FBC Management		
<b>Y</b>	Optical Connector Type <sup>3</sup>		
<b>S</b>	SC/APC <sup>(2)</sup>		
<b>E</b>	E2000/APC		
<b>F</b>	FC/APC		
<b>L</b>	LC/APC		

#### Note:

- Option for FBC Management configurations only, if not used omit X when making an order.
- Standard option. Contact a Technetix sales representative for availability of other options.